

**DCZ-600-A-EVOLUTION 2014-2015**

NO	MMA 01 420 200	REV	1	DATE	2015/02/12
----	----------------	-----	---	------	------------

#	Order nr	article description	quantity
210	MMA 01 420 210		1
220	MMA 01 420 220		1
230	MMA 01 420 230		1
240	MMA 01 420 240		1
250	MMA 01 420 250		1
260	MMA 01 420 260		1
270	MMA 01 420 270		1
280	MMA 01 420 280		1

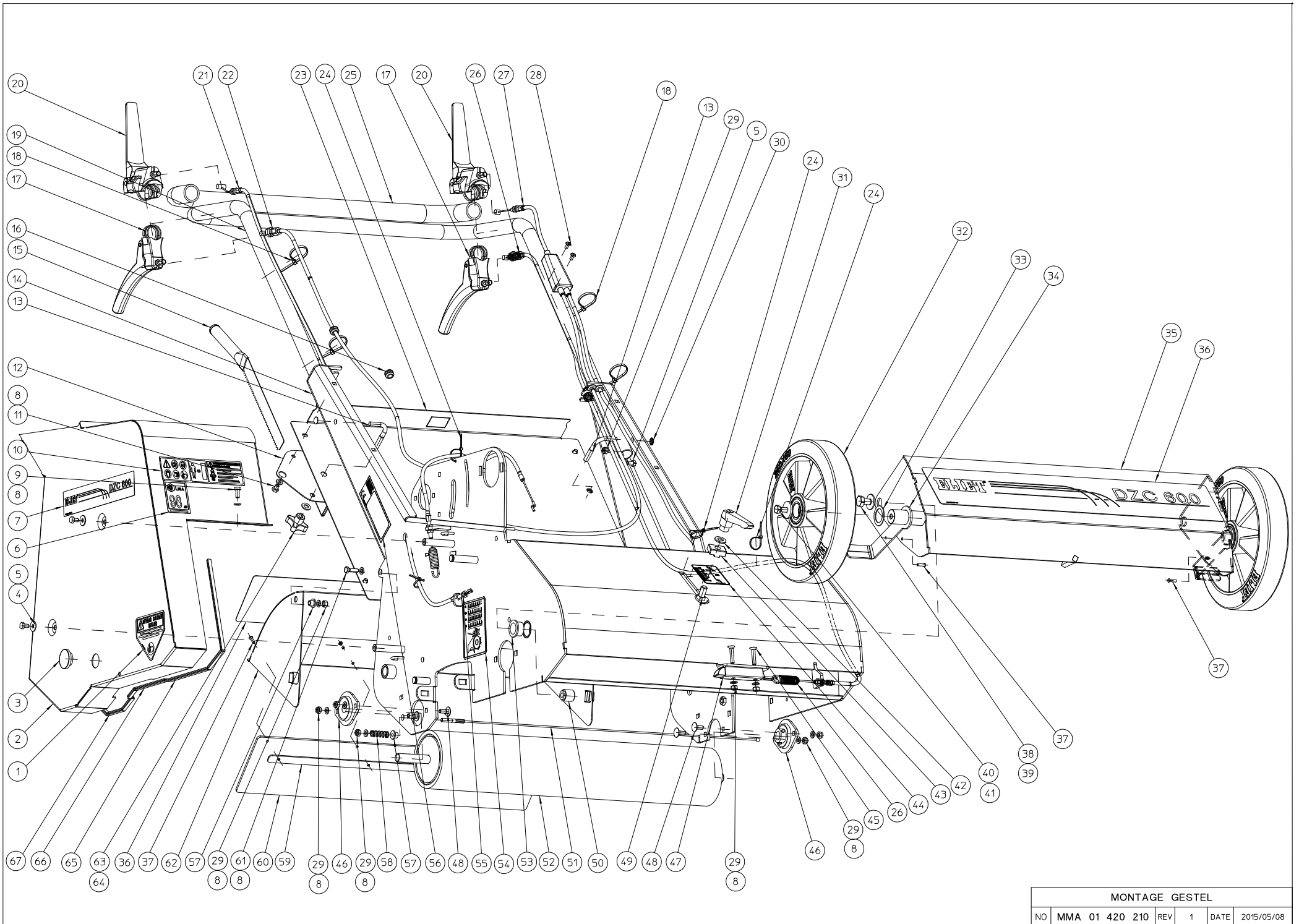

MONTAGE GESTEL					
NO	MMA 01 420 210	REV	1	DATE	2015/05/08

#	Order nr	article description	quantity
1	BQ 505 010 070	safety sticker 100x80 (hand cuts)	1
2	MPA 01 420 310		1
3	BR 500 102 500	rubber plug 25x2	1
4	BS 532 006 183	washer m6x18x1.5	2
5	BS 512 000 610	bolt m6x10 din 933	4
6	BQ 505 112 098	sticker sound level 98 db	1
7	BQ 501 251 010	label-dzc600 250x44	1
8	BS 531 000 600	washer m6 din 125	16
9	BS 512 000 614	bolt m6x14 din 933	1
10	BQ 505 010 171	safety sticker 70x115 (pictogram)	1
11	BS 512 000 608	bolt m6x8 din 933	4
12	MPA 01 420 235	tool holder	1
13	MPA 01 420 095	steer clamp	2
14	MPA 01 420 305		1
15	MPA 01 350 495	roll purifier	1
16	BR 000 208 030	rubber grommets 8/3	2
17	BN 332 500 350	control handle	2
18	BE 043 010 140	wrap tie 140x3.5	4
19	MPA 01 420 245		1
20	BN 332 500 140	control handle	2
21	BK 153 181 460	control cable drive knives	1
22	BK 153 181 220	control cable tractionroll	1
23	MPA 01 420 190	closing plate	1
24	BE 043 010 100	wrap tie 100x2.5	4
25	BN 231 002 073	soft rubber grip dia 24.5mm (l=730mm)	1
26	BK 153 180 350	cable operating latch	1
27	BK 153 181 751		1
28	BB 221 005 100	pop plug steel 4.8x10 din 7337 a	2
29	BS 502 000 600	self locking nut m6 din 985	11
30	BB 011 000 070	starlock 7mm	2
31	BN 530 110 830	clamp handle with internal thread m10	1
32	BW 325 025 000	rear wheel alu 250/50-60 (e 501 pro)	2
33	BS 036 002 510	fitting ring 25x35x1mm din 988	2
34	MPA 01 420 100	wheel scraper	2
35	MPA 01 420 260	hinge shell wheels	1
36	BQ 501 251 020	label-dzc600 250x44	2
37	BB 221 104 140	pop plug alu 3.9x14 din 7337 a	6
38	BS 512 001 016	bolt m10x16 din 933	2
39	BS 532 010 274	washer m10x27x2	2
40	BS 512 000 820	bolt m8x20 din 933	2
41	BS 532 008 306	washer m8x30x3	2
42	BS 531 001 000	washer m10 din 125	1
43	MPA 01 420 090	stopper depth control	1
44	BQ 501 251 080		1
45	BS 522 100 630	screw m6x30 din 7991	2
46	BL 801 101 500	bearing + flanges aspfl 202	2
47	BO 360 505 180	draw-bolt 0°	1
48	BS 554 100 616	bolt m6x16 din 603	4
49	BS 554 101 025	bolt m8x60 din603	1
50	MPA 01 420 105	hinge axis shell	2
51	BK 155 250 630	cable 2,5x 49 x 630mm	1
52	MPA 01 350 515	coated tractionroll	1

53	BR 112 201 500	nylon bushing with collar (20/24/30x15/2)	2
54	BQ 505 010 130	safety sticker 100x80 (belt transmission)	1
55	BS 501 900 600	nut m6 din 439	1
56	BQ 505 010 010	identity sticker ce 120x30	1
57	BR 112 060 800	nylon bushing with collar (6/10/15x8.5/2)	3
58	BV 925 000 010	compression spring 1,3 x 11 x 33,6	1
59	MPA 01 420 330		1
60	BR 900 001 680		1
61	BS 512 000 620	bolt m6x20 din 933	2
62	MPA 01 420 115	protective shell behind	1
63	BN 630 808 400	lob knob 188-40 m8	2
64	BS 531 000 800	washer m8 din 125	2
65	BR 000 910 370	rubber u-moulding 370mm	1
66	BR 000 910 130	rubber u-moulding 130mm	1
67	BR 000 910 700	rubber u-moulding 700mm	1

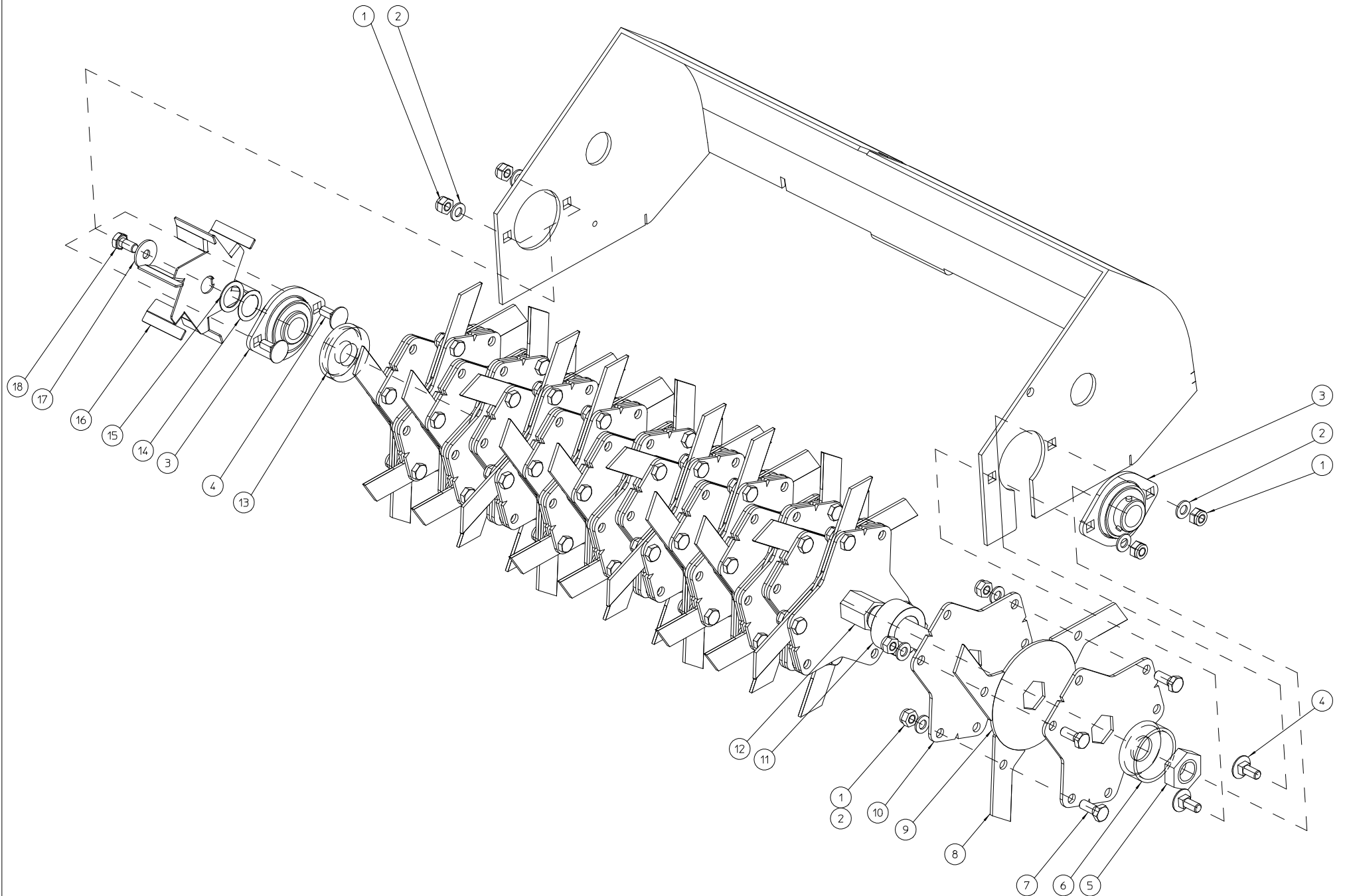

MONTAGEPLAN MESSENAS DZC-600						
NO	MMA 01 420 220	REV	1	DATE	2014/10/21	

#	Order nr	article description	quantity
1	BS 502 000 800	self locking nut m8 din 985	61
2	BS 531 000 800	washer m8 din 125	61
3	BL 801 102 002	bearing + flanges ucpfl 204	2
4	BS 554 100 820	bolt m8x20 din 603	4
5	BS 501 902 200	nut m22x1.50 din 439	1
6	MPA 01 420 055	support washer blade right	1
7	BS 512 000 820	bolt m8x20 din 933	57
8	BU 102 200 300	loose blade dzc 600	57
8	BU 402 300 157	SET 57 VITI+ LAME DZC600 PSB	1
8	BU 402 303 357	SET 57 VITI+LAME AL CARBURO DZC600	1
9	MPA 01 420 035	spacer knife	19
10	MPA 01 420 265	knife plate	38
11	MPA 01 420 060	spacer knife plate	18
12	MPA 01 420 045	blade shaft	1
13	MPA 01 420 050	support washer blade left	1
14	BS 036 002 005	fitting ring 20x28x0.5mm din 988	1
15	BS 036 002 010	fitting ring 20x28x1mm din 988	1
16	MPA 01 420 135	fan helix	1
17	BS 532 008 254	washer m8x25x2	1
18	BS 512 170 816	bolt left hand thread m8 x 1.25	1

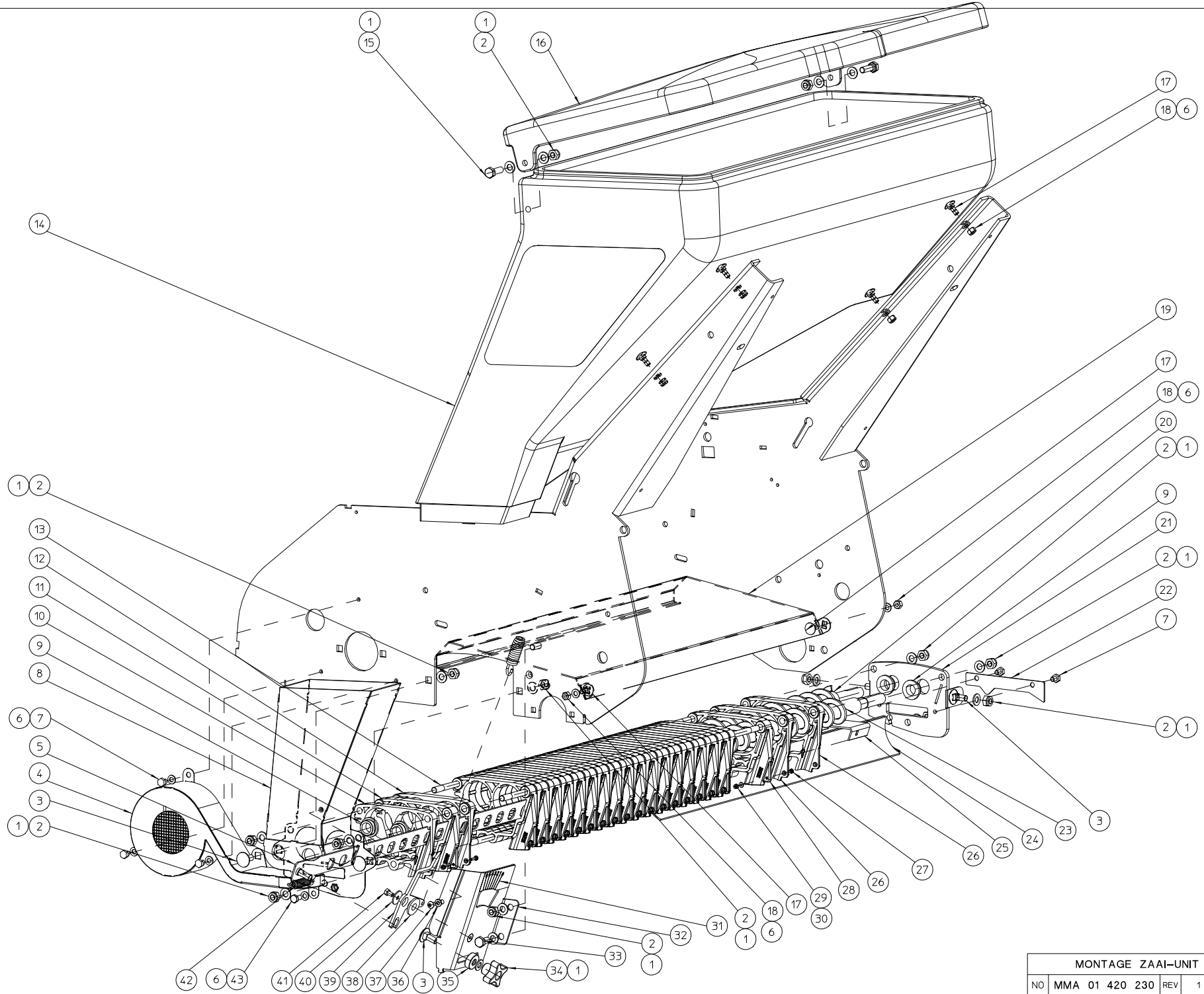

MONTAGE ZAAI-UNIT DZC-600						
NO	MMA 01 420 230	REV	1	DATE	2015/07/03	

#	Order nr	article description	quantity
1	BS 531 000 800	washer m8 din 125	17
2	BS 502 000 800	self locking nut m8 din 985	13
3	BS 554 100 820	bolt m8x20 din 603	5
4	MPA 01 420 130	fan housing	1
5	MPA 01 420 150	dosing plate	1
6	BS 531 000 600	washer m6 din 125	10
7	BS 512 000 608	bolt m6x8 din 933	5
8	MPA 01 420 280	seed hopper	1
9	BR 112 151 090	slide bearing	4
10	BR 930 040 050		1
11	BR 930 040 040		18
12	BR 930 040 030		18
13	MPA 01 420 070	clamprod	3
14	BR 930 040 010	seed container	1
15	BS 512 000 825	bolt m8x25 din 933	2
16	BR 930 040 020	cover seed container	1
17	BS 554 100 616	bolt m6x16 din 603	6
18	BS 502 000 600	self locking nut m6 din 985	6
19	MPA 01 420 140	protection seed unit	1
20	MPA 01 420 205		1
21	MPA 01 420 075	closing plate right dosing unit	1
22	MPA 01 420 180		1
23	MPA 01 420 270		1
24	BY 431 306 059		1
25	MPA 01 420 230		1
26	BR 930 040 060	dispensing unit left	2
27	BS 512 000 312	bolt m3x12 din 933	19
28	BR 930 040 070	dispensing unit right	1
29	BS 502 000 300	self locking nut m3 din 985	19
30	BS 531 000 300	washer m3 din 125	19
31	BQ 501 251 090		1
32	MPA 01 420 285		1
33	BS 512 000 816	bolt m8x16 din 933	1
34	BN 630 808 400	lob knob 188-40 m8	1
35	MPA 01 420 225		1
36	BS 531 000 500	washer m5 din 125	1
37	BS 522 500 508	screw m5x8 iso 7380	1
38	BR 112 100 600	nylon bushing with collar (10/13.5/25x6/2.5)	1
39	MPA 01 420 290		1
40	BS 532 005 202	washer m5x20x1.5	1
41	BS 512 000 508	bolt m5x8 din 933	1
42	BV 912 000 010	recall spring	1
43	BS 512 000 612	bolt m6x12 din 933	1

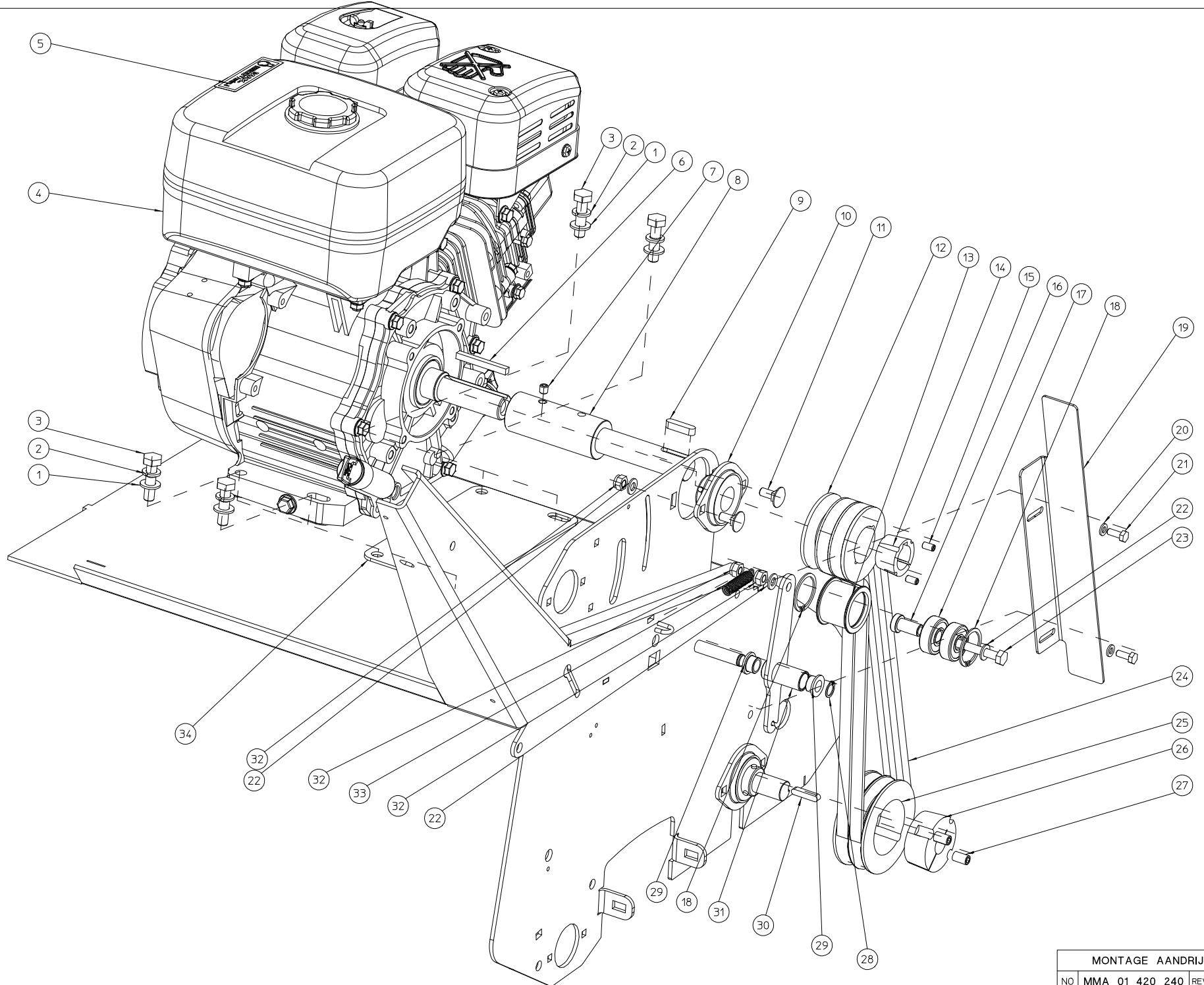

MONTAGE AANDRIJVING MESSENAS						
NO	MMA 01 420 240	REV	1	DATE	2014/10/17	

#	Order nr	article description	quantity
1	BS 531 001 000	washer m10 din 125	4
2	BS 533 001 000	lock washer m10 din 127b	4
3	BS 511 001 040	bolt m10x40 din 931	4
4	BM 204 109 000	subaru ex27	1
5	BQ 505 010 020	sticker max 2800 rpm 90x25	1
6	BB 342 060 657	key 6.35x6.35x57 din 6880	1
7	BS 023 000 808	set screw m8x8 din 916	1
8	MPA 01 350 125	extention engineshaft	1
9	BB 351 080 732	key 8x7x32 din 6885a	1
10	BL 801 102 500	bearing + flanges aspfl 205	1
11	BS 554 100 820	bolt m8x20 din 603	2
12	BA 562 707 130	pulley spa iii 71 tl1108	1
13	MPA 01 350 030	pressure roller belt tightener	1
14	BB 501 112 500	taper lock tl 1108-25	1
15	BB 501 306 130	set screw 1/4"x1/2"	2
16	MPA 01 350 040	spacer belt tightener galvanized	1
17	BL 001 203 703	bearing 6301 2rz	2
18	BB 002 000 370	retaining ring 32 din 472	2
19	MPA 01 420 255		1
20	BS 531 000 600	washer m6 din 125	2
21	BS 512 000 616	bolt m6x16 din 933	2
22	BS 531 000 800	washer m8 din 125	4
23	BS 511 000 844	bolt m8x60 din 931	1
24	BA 527 709 910	belt 4l 330	2
25	BA 562 709 021	pulley spa ii 90 tl1610	1
26	BB 501 132 000	taper lock tl 1610-20	1
27	BB 501 310 160	set screw 3/8"x5/8"	2
28	BB 001 000 120	retaining ring 12 din 471	1
29	BR 112 121 090	nylon bushing with collar (12/16/22x10/2)	2
30	BB 351 060 630	key 6x6x30 din 6885a	1
31	MPA 01 420 250		1
32	BS 502 000 800	self locking nut m8 din 985	4
33	BV 011 011 005	spring 1x11x55	1
34	BR 901 202 203	vibration damper	1

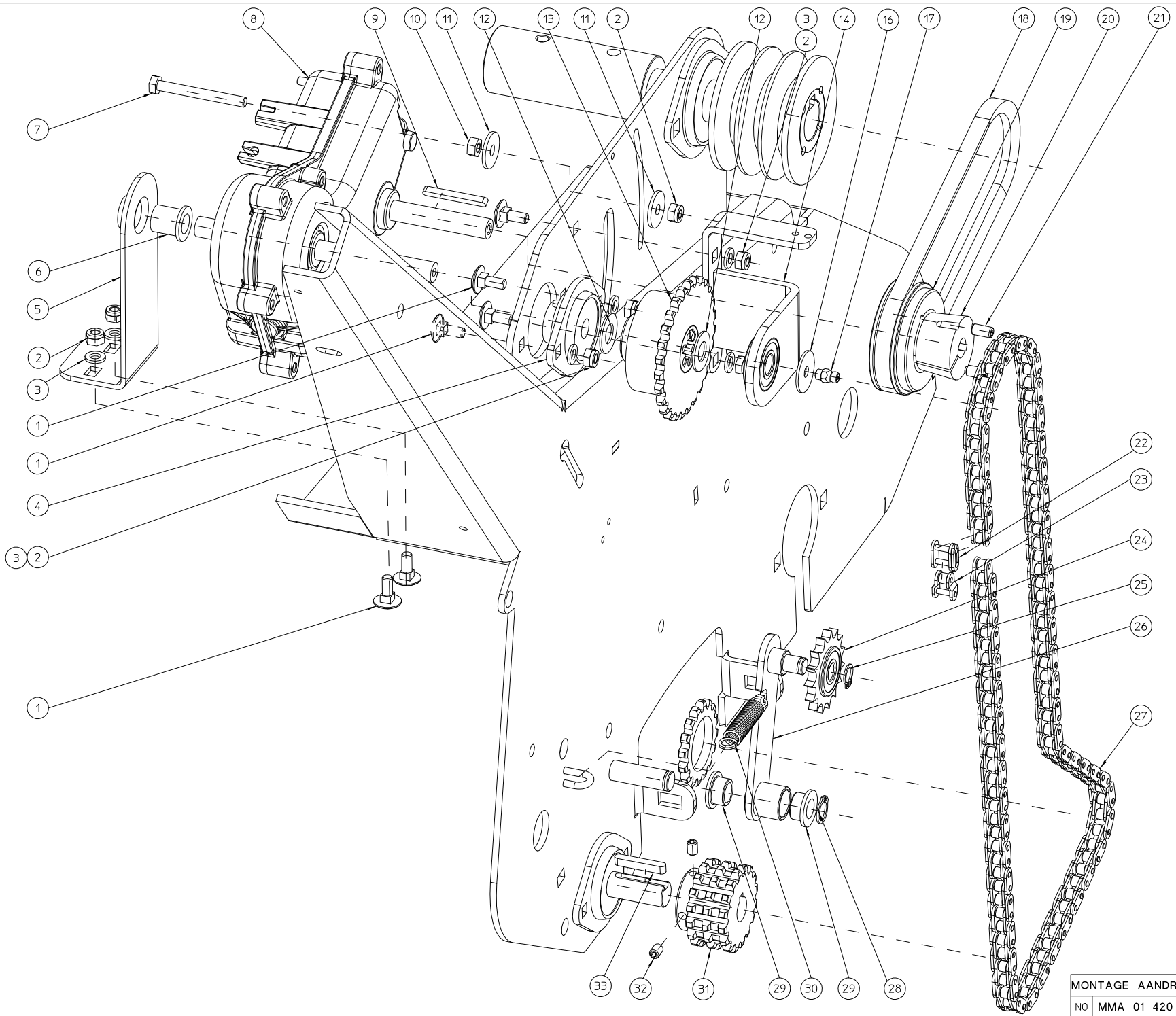

MONTAGE AANDRIJVING TRACTIEROL-DZC-600						
NO	MMA 01 420 250	REV	1	DATE	2015/09/12	

#	Order nr	article description	quantity
1	BS 554 100 616	bolt m6x16 din 603	6
2	BS 502 000 600	self locking nut m6 din 985	7
3	BS 531 000 600	washer m6 din 125	6
4	BL 801 101 200	bearing + flanges aspf1 201	1
5	MPA 01 350 135	support gear box	1
6	BR 112 121 900	nylon bushing with collar (12/16/21x19/2)	1
7	BS 512 000 643	bolt m6x55 din 933	1
8	BA 670 405 405	reduction gearboxes e600 compactor	1
9	BB 351 040 440	key 4x4x40 din 6885a	1
10	BS 501 000 600	nut m6 din 934	1
11	BS 532 006 224	washer m6x22x2	2
12	BR 111 120 100	nylon bushing (12.2x24x1.3)	2
13	BA 171 027 289	sprocket simplex 3/8"x7/32" 27t + clutch mechanism	1
14	MPA 01 420 405		1
16	BS 532 006 253	washer m6x25x1.5	1
17	BY 100 106 100	grease fitting m6 din 71412	1
18	BA 521 404 870	belt z 487	1
19	BA 561 706 310	pulley spz 63 tl1108	1
20	BB 501 111 200	taper lock tl 1108-12	1
21	BB 501 306 130	set screw 1/4"x1/2"	2
22	BA 151 200 000	connecting chain link simplex 3/8"x7/32"	1
23	BA 151 400 000	connecting chain link simplex (1/2) 3/8"x7/32"	1
24	BA 198 010 150	sprocket simplex 3/8"x7/32" 15t + bearing	1
25	BB 001 000 100	retaining ring 10 din 471	1
26	MPA 01 420 110		1
27	BA 101 111 020	chain simplex 3/8"x7/32" 111l	1
28	BB 001 000 120	retaining ring 12 din 471	1
29	BR 112 121 090	nylon bushing with collar (12/16/22x10/2)	2
30	BV 011 311 005	spring 1,3x11x55	1
31	BA 172 016 150	sprocket triplex 3/8"x7/32" 16t	1
32	BS 023 000 608	set screw m6x8 din 916	2
33	BB 351 050 532	key 5x5x32 din 6885a	1

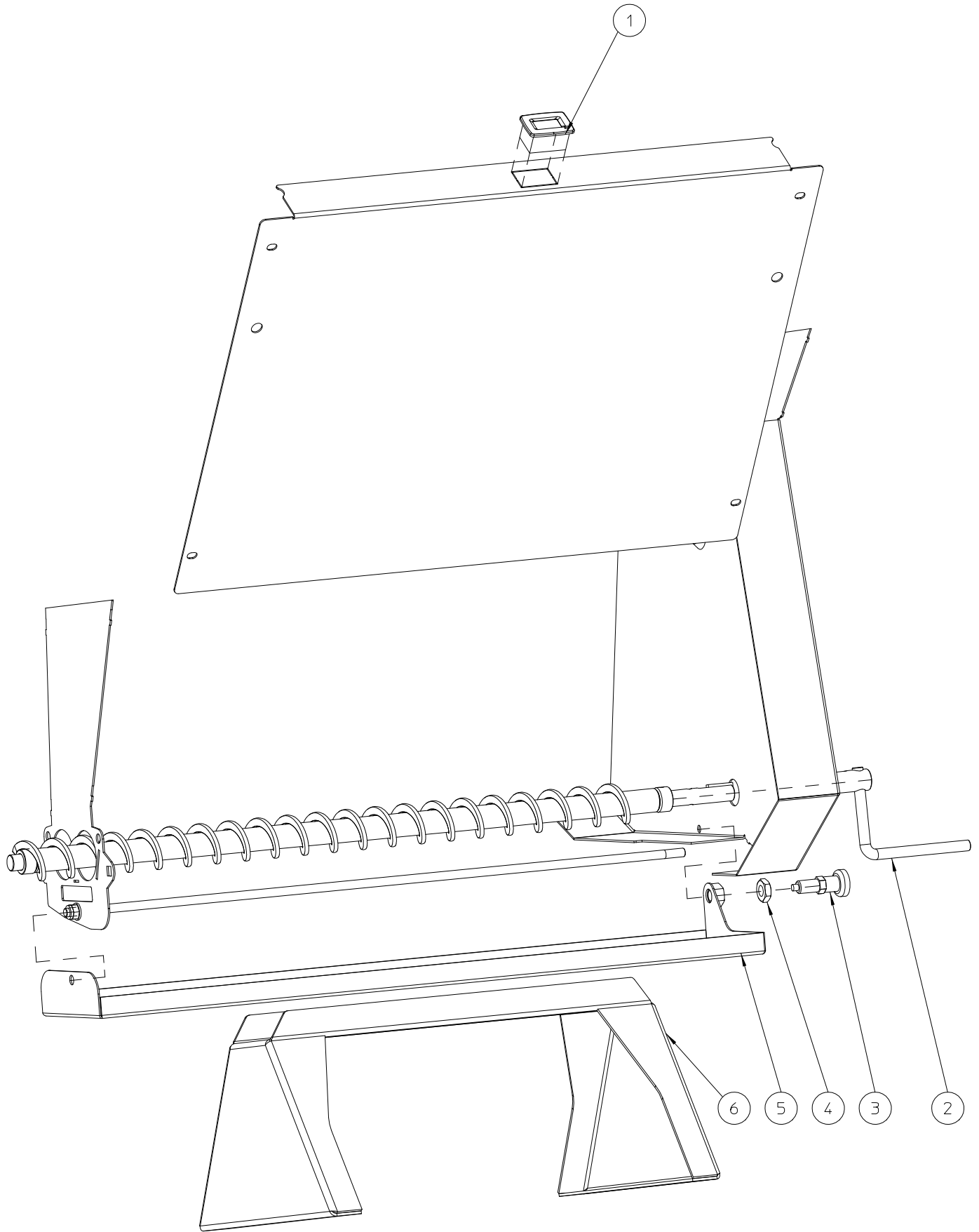

OPTIES DZC-600					
NO	MMA 01 420 260	REV	1	DATE	2014/12/13

#	Order nr	article description	quantity
1	BE 412 430 000	maintenance meter	1
2	MPA 01 420 120		1
3	BN 000 212 550	locking bolts with locking groove	1
4	BS 501 901 202	nut m12x1 din 439b	1
5	MPA 01 420 185		1
6	MPA 01 420 220	easy clean	1

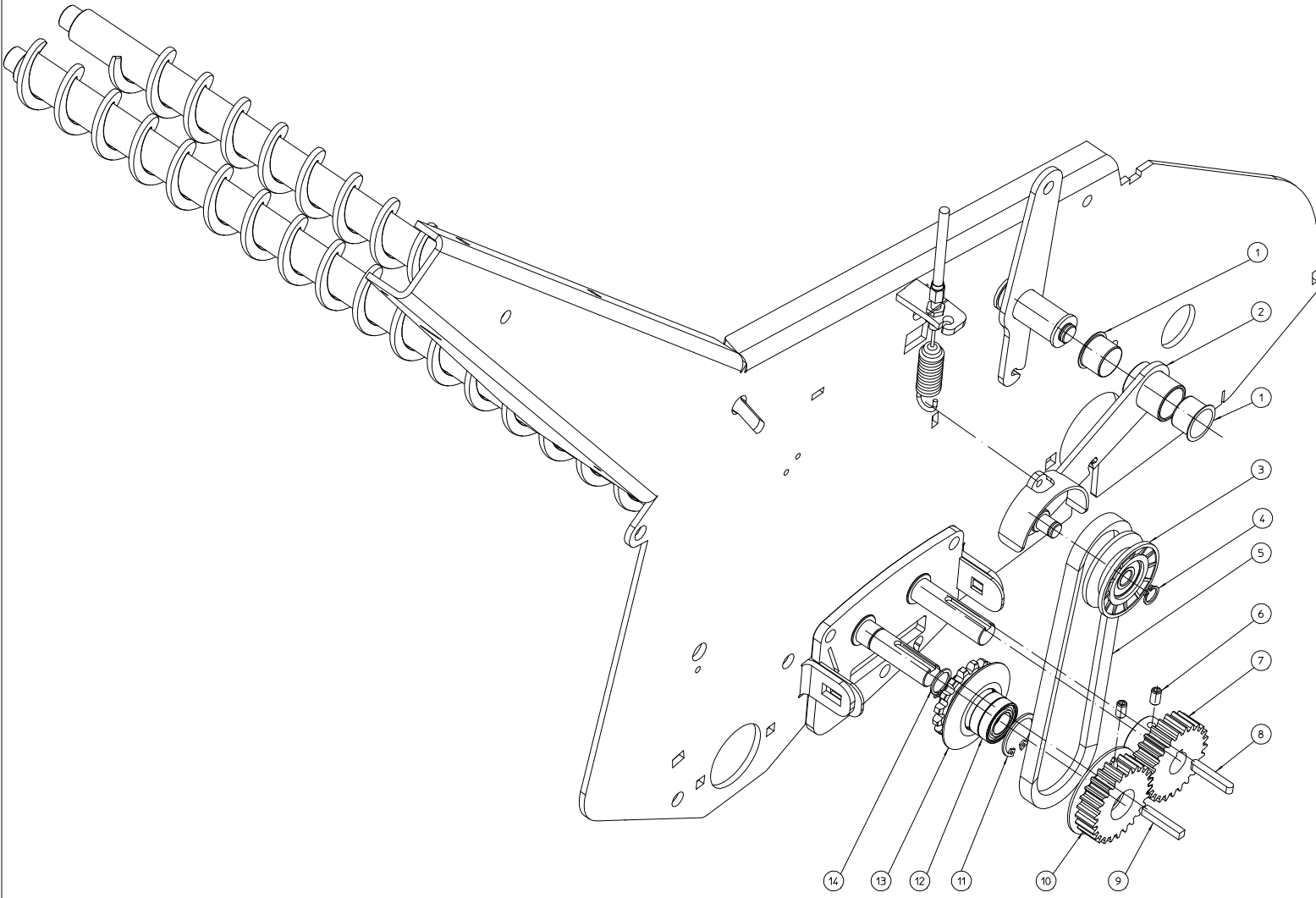

AANDRIJVING ARCHIMEDESSCHROEF						
NO	MMA 01 420 270	REV	1	DATE	2014/10/17	

#	Order nr	article description	quantity
1	BR 112 201 590	nylon bushing with collar	2
2	MPA 01 420 240		1
3	BA 599 094 350	idler roller vØ50	1
4	BB 001 000 100	retaining ring 10 din 471	1
5	BA 521 404 870	belt z 487	1
6	BS 023 000 610	set screw m6x10 din 916	4
7	BA 602 002 502	gear m2 25t l=31mm	1
8	BB 351 050 532	key 5x5x32 din 6885a	1
9	BB 341 050 530	key 5x5x30 din 6880	1
10	MPA 01 420 320	gear	1
11	BB 002 000 280	retaining ring 28 din 472	1
12	BL 001 502 803	bearing 6902 llu	2
13	MPA 01 420 315	Gear 3/8 16T+1/2PUL.	1
14	BB 001 000 150	retaining ring 15 din 471	1

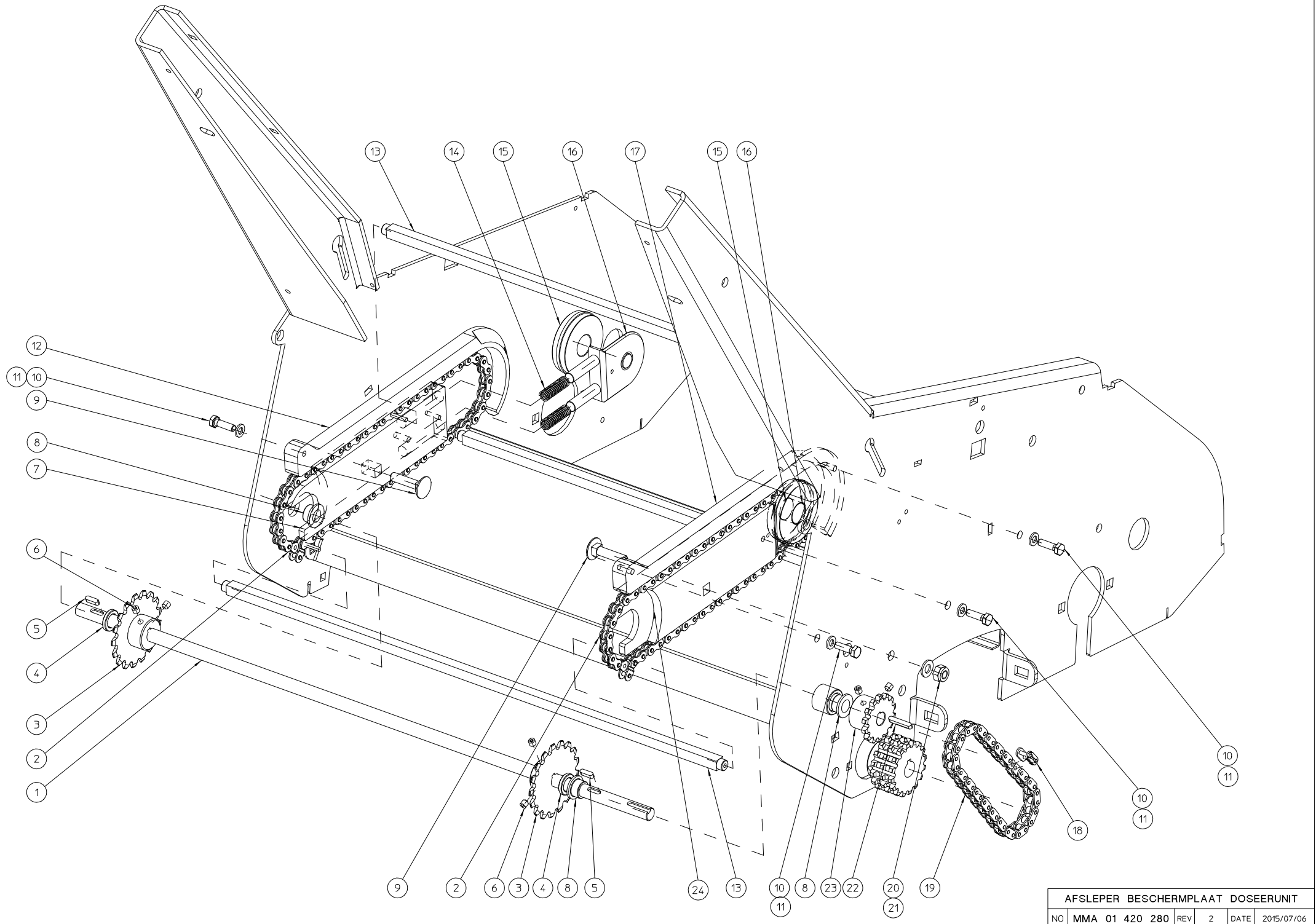

AFSLEPER BESCHERMPLAAT DOSEERUNIT

NO	MMA 01 420 280	REV	2	DATE	2015/07/06
----	----------------	-----	---	------	------------

#	Order nr	article description	quantity
1	MPA 01 420 360		1
2	BA 111 054 010	chain 1/2' x 1/8' 54 s	2
3	BA 181 017 121	sprocket 17t 1/2"x 1/8" simplex	2
4	MPA 01 420 380		2
5	BB 351 040 414	key 4x4x14 din 6885a	2
6	BS 023 000 606	set screw m6x6 din 916	6
7	MPA 01 420 420		1
8	BR 112 121 090	nylon bushing with collar (12/16/22x10/2)	3
9	BS 554 100 835	bolt m8x35 din 603	2
10	BS 512 000 620	bolt m6x20 din 933	6
11	BS 531 000 600	washer m6 din 125	6
12	MPA 01 420 430		1
13	MPA 01 420 385		3
14	BV 907 000 020	spring 10x1x60	4
15	BR 910 000 830	tensioning wheel	2
16	MPA 01 420 410		2
17	MPA 01 420 425		1
18	BA 151 200 000	connecting chain link simplex 3/8"x7/32"	1
19	BA 101 039 020	chain simplex 3/8"x7/32" 39l	1
20	BS 502 000 800	self locking nut m8 din 985	1
21	BS 531 000 800	washer m8 din 125	1
22	BB 351 040 425	key 4x4x25 din 6885a	1
23	BA 171 014 120	sprocket simplex 3/8"x7/32" 14t	1
24	MPA 01 420 415		1